

TRAKER T95

MINIDUMPER

CAPACITÀ OPERATIVA
OPERATING WEIGHT
900 kg · 1984 lbs

LARGHEZZA AI CINGOLI
TRACK WIDTH
780 mm · 27.9 inch

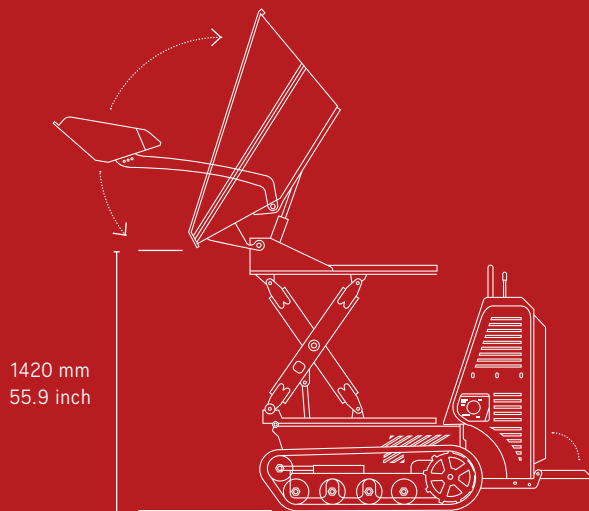
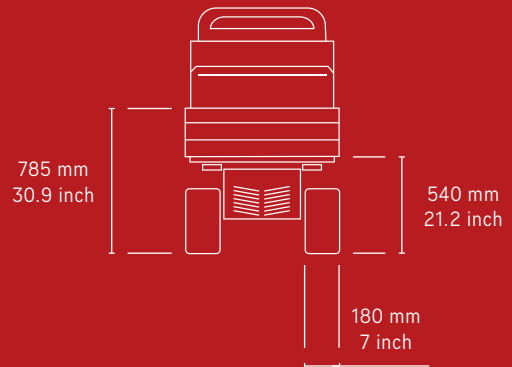
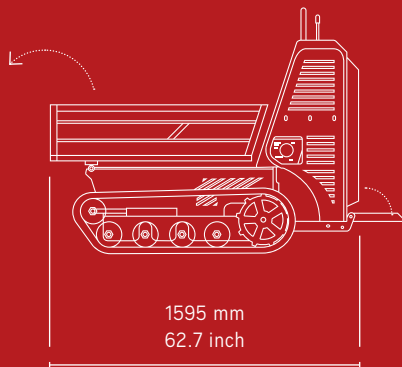
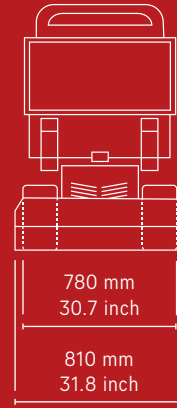
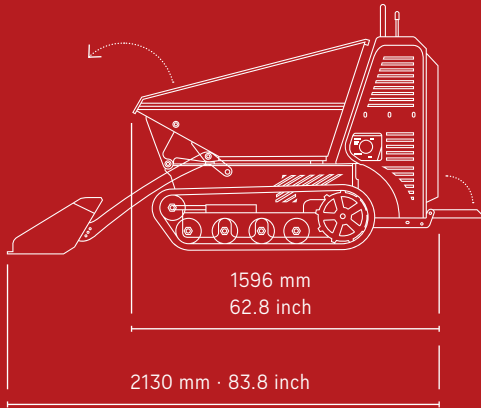

MOTORE TERMICO
ENGINE
→ HONDA GX390AE
→ YANMAR L100N

TRASMISSIONE
TRANSMISSION
→ IDROSTATICA
→ HYDROSTATIC

POMPA IDRAULICA
HYDRAULIC PUMP
→ 2 x PORT. VAR. + 1 POMPA INGR
→ 2 x VAR. DISPL. + 1 GEAR PUMP

MOTORE IDRAULICO
HYDRAULIC MOTOR
2 x ORBITALI
2 x ORBITAL

PORTATA POMPA
PUMP FLOW RATE
→ 2x35 l/min + 1 POMPA INGR
→ 2x9.3 gpm + 1 GEAR PUMP

PRESSIONE MASSIMA
MAX PRESSURE
180 bar

RAFFREDDAMENTO IDRAULICO
HYDRAULIC COOLING SYSTEM
ARIA
AIR

LARGHEZZA CINGOLI
TRACK WIDTH
180 mm
7 inch

RULLI
TRACK ROLLERS
→ 4

RULLI OSCILLANTI
ROCKING ROLLERS
SI
YES

REGOLAZIONE CINGOLI
TRACK TENSIONER
SI
YES

VELOCITÀ DI TRASLAZIONE
TRAVEL SPEED
→ 5 km/h
→ 3.1 mp/h

CAPACITÀ OPERATIVA
OPERATING WEIGHT
→ 900 kg / 1984 lbs
HIGH-TIP
→ 800 kg / 1763 lbs

MASSA A VUOTO
EMPTY WEIGHT
530 kg
1168 lbs

CONTROLLO
CONTROL
→ MONOJOYSTICK

CARATTERISITCHE TECNICHE / TECHNICAL FEATURES

 RASO 0.30 m³
STRUCK 0.39 yd³

 COLMO 0.36 m³
HEAPED 0.45 yd³

 RASO 0.17 m³
STRUCK 0.22 yd³

 COLMO 0.25 m³
HEAPED 0.32 yd³

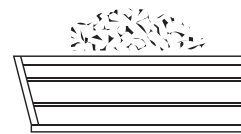
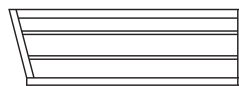
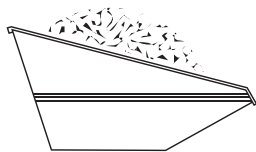
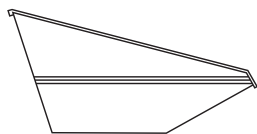

 RASO 0.28 m³
STRUCK 0.37 yd³

 COLMO 0.36 m³
HEAPED 0.47 yd³

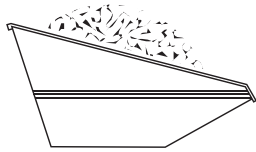
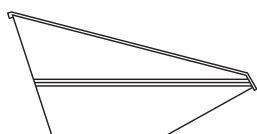

CAPACITÀ / CAPACITY